

Unit 4 Reading: Force Diagrams

The analysis of a problem in dynamics usually involves the selection and analysis of the relevant forces acting on some object under consideration. An important first step in this analysis process is to carefully select the object of interest. For purposes of this analysis, we will refer to the object under consideration as the **system**, and everything else in the environment that might in any significant way affect the system as the **surroundings**. This analysis process can often times be greatly simplified by utilizing a technique of constructing **force diagrams** to assist you in selecting the relevant forces and appropriately representing these forces with **vector** notations.

For the purpose of developing a force diagram for problem analysis, all forces will be categorized as either **contact** or **long range** forces. **Contact forces** are all forces acting on the system that result from the contact between the system and its surroundings. These forces include forces of static and kinetic friction, tension forces and normal forces. **Long range** forces result from the system's interaction with a force field of some kind, such as magnetic, electric or gravitational fields.

Consider, for example, the forces acting on a block being pulled along a horizontal table top by a string attached to the block, passing over a pulley, and terminating with several masses attached to the string by a mass hanger. (See Figure 1).

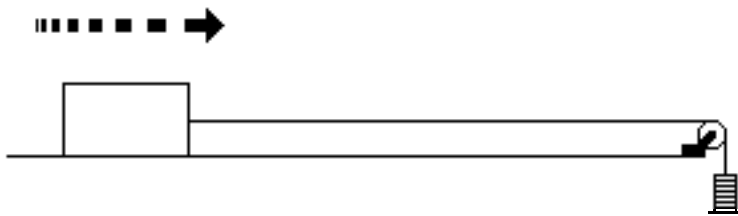

Notice first that the block makes direct contact with both the surface that it is sliding over and with the string. The block, additionally, interacts with its surroundings by way of its interaction with the earth's gravitational field. As the block slides along the surface, there is one component of force resulting from the sliding action that acts parallel to the surface

Figure 1

and in a direction opposite to the direction of motion (resists the sliding motion). This component of surface contact force is designated as the force of kinetic friction^{*}. In addition to the parallel component of force resulting from the sliding surface contact (frictional force), there is also a perpendicular (normal) component that is the result of the table pushing upward against the block to hold it up. Our analysis indicates that there is another contact force (tension force) applied to the block through the string. These forces are all examples of contact forces that result from events that occur at the system boundary. In addition to these forces, it should be noted that the system experiences an interaction with the earth (weight), by way of a long range gravitational force. This attractive force results from the long range interaction between the block and the earth by way of the earth's gravitational field.

All of the forces, as discussed in the preceding paragraph, and how they are related to one another are difficult to keep straight in our minds. Thus, an analysis of relevant forces is much more meaningful when it includes a sketch of the system, with vector representations for the relevant forces. The force vector and the agent that gave rise to that vector are labeled with an appropriately subscripted symbol. For example, the vector representing the force of gravity would be designated as \mathbf{F}_g , the vector representing the force exerted on the system by the string (tension force) would be

^{*} Frictional forces resist movement when two surfaces in contact have relative motion (i.e. a car locking its brakes and sliding to a stop or a drag racer spinning its wheels as it accelerates). These forces are called forces of kinetic friction (\mathbf{F}_k). Frictional forces may also, however, resist movement when two surfaces in contact do not have relative motion (i.e. the force that resists motion when pushing on a stationary object sitting on a table or the force of a tire pushing backward against the road when a car is accelerating without spinning its tires). These forces are called forces of static friction (\mathbf{F}_s).

designated as F_T , the force of kinetic friction as F_k , etc. Finally, constructing a set of coordinate axes on the diagram would provide a frame of reference without which the object's motion could not be adequately described.

Consider the analysis of forces acting on a log as a tractor pulls it at a constant speed (Figure 2 below). The analysis proceeds as follows:

1. Sketch the system and its surroundings.
2. Enclose the system within a system boundary.
3. Represent all relevant forces (across the system boundary) by a vector labeled with an appropriate symbol.
4. Add coordinate axes with one axis parallel to the direction of motion.

As an illustration of this process, consider the forces acting on a log being pulled by a tractor follows:

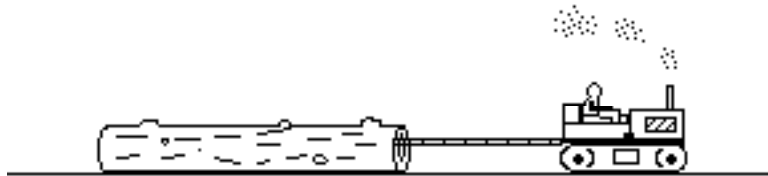

Figure 2

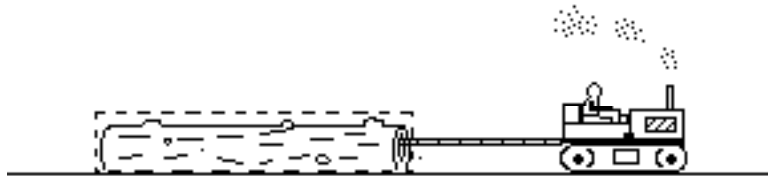
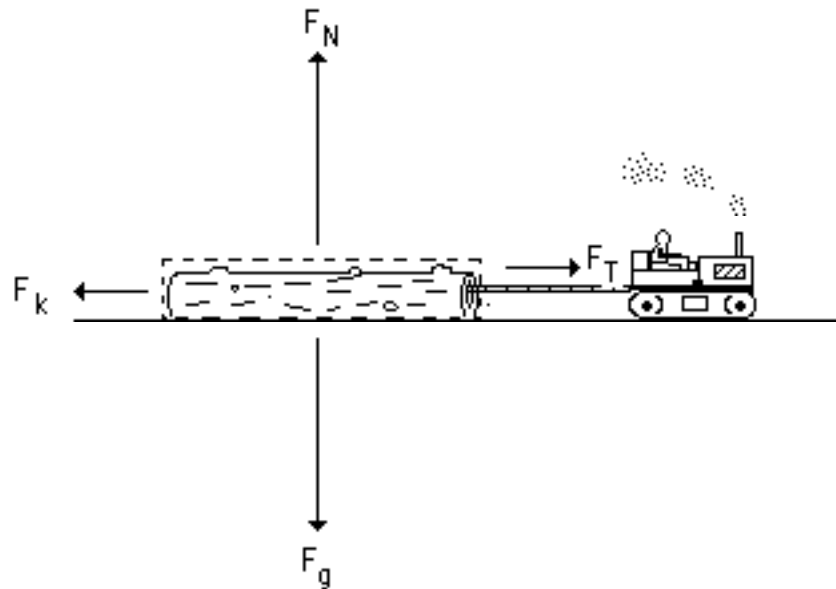

Figure 3



See Figure 4 above.

Step 1

Sketch a diagram of the system and its surroundings as illustrated in Figure 2.

Step 2

In order to assist in the identification of the relevant forces acting on the system, enclose the system (log) within a closed boundary line (Figure 3).

Step 3

Proceed around the system boundary line and identify all points at which there is contact between the system (log) and its surroundings. Construct qualitative vectors (indicate directions and **relative** magnitudes) to represent these forces. The contact forces would be kinetic friction, F_k (parallel to the supporting surface), the normal force, F_N (the component of force that is perpendicular to the supporting surface), and the tension force of the rope, F_T . The long range force(s), in this case would be only the force of gravity, F_g .

Step 4

Considering the system only (log), construct a set of coordinate axes with *one axis parallel to the direction of motion* as shown in Figure 5.

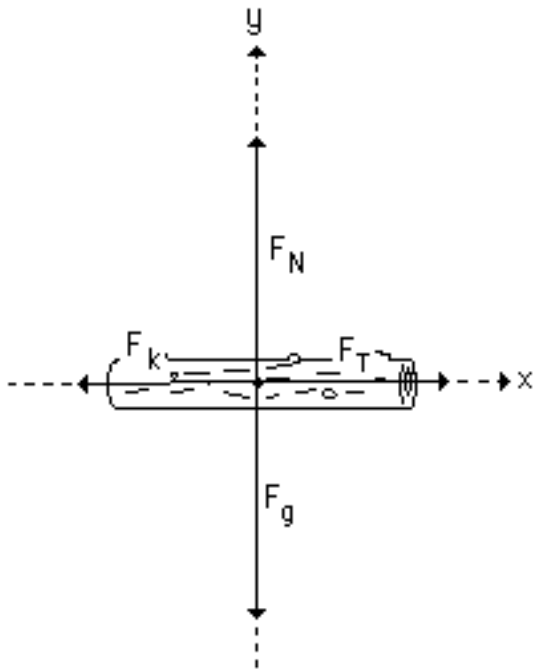

Now it should be easy to determine the forces on the object. To do this, consider the force in each direction (x or y) separately.

That is:

x-axis	y-axis
F_T and F_k	F_g and F_N

Since the log is moving at a constant velocity in the x-direction:

$$\begin{aligned}\Sigma F_x &= 0 \\ F_T + F_k &= 0 \\ F_T &= -F_k\end{aligned}$$

Since the log is not moving in the y-direction:

$$\begin{aligned}\Sigma F_y &= 0 \\ F_N + F_g &= 0 \\ F_N &= -F_g\end{aligned}$$

Figure 5

Thus, by knowing F_g and F_k , we can find F_N and F_T .

Consider the block sliding down a frictionless ramp.

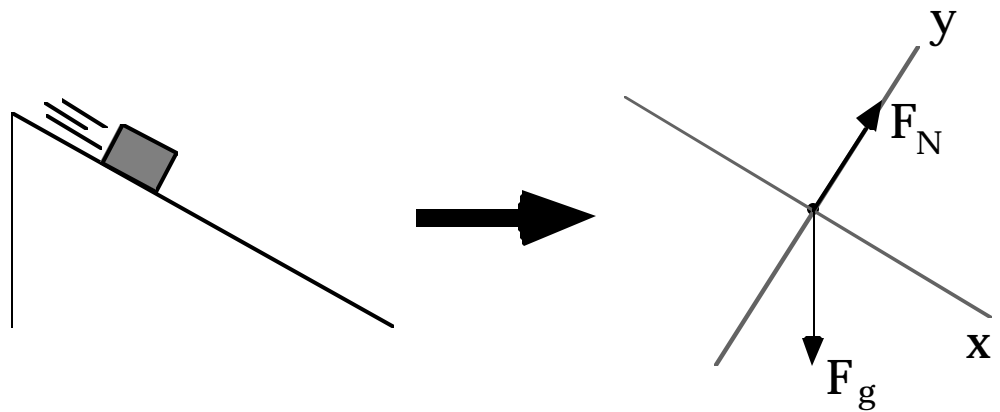

To simplify the drawing of the force diagram, use a **point** to represent the object. Note that we have rotated the coordinate axes as shown above so that the x-axis is *parallel to the direction of motion*.

Next, break any force vector which is not parallel to the coordinate axes (in this case, the force of gravity, \mathbf{F}_g) into its x and y components. See the diagram at right. Note that the x -component and y -component form the sides of a right triangle with the original force vector, \mathbf{F}_g as the hypotenuse.

In this case, the y -component cancels out the normal force \mathbf{F}_N , so the object does not accelerate into or off of the ramp. The x -component of \mathbf{F}_g is the only force acting in the x -direction, so the object accelerates in the positive x -direction.

To determine the **magnitudes** of F_x and F_y , you need to use some simple trigonometry. There are just a few points to keep in mind.

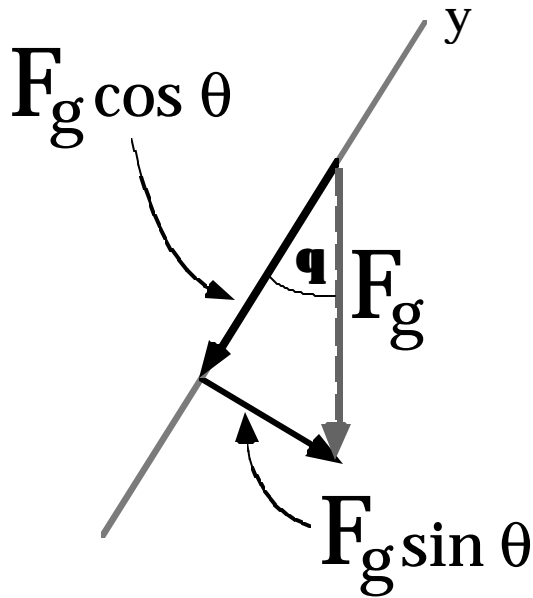
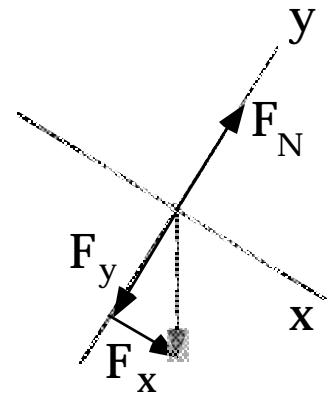

1. The angle θ should be drawn so that it is included in the triangle formed by the three vectors.
2. The side **opposite** the angle has magnitude equal to the original vector times the **sine** of the angle.
3. The side **adjacent** to the angle has magnitude equal to the original vector times the **cosine** of the angle.